



April 2009

KEMLAN COUPE DOUBLE SIDED FIREPLACE BUILT IN MODEL

INTRODUCTION

•This Fire is suitable for installation on properties over 2HA in size.

•BUILDING CONSENTS (PERMITS)

It is the house owners responsibility to have the correct permit lodged and accepted by the local building authority. Your Installer may offer to assist with this and in some cases undertake the complete application, lodgement, payment, etc. on your behalf (a fee maybe incurred).

•INSTALLATION

All solid fuel heating appliances sold by Broadys NZ Ltd must be installed to the requirements of the **Standard AS/NZS 2918:2001** and the product instructions supplied by us and/or with the appliance. This includes the "FINISHING" of your installation e.g. the correct venting, hearth sizing, and fascia and/or mantle surrounds.

Broady's NZ Limited do not undertake installation and/or site work associated with the installation of the products we sell, nor warrant their installation. We recommend that the installation of all solid fuel heating appliances be carried out by a Qualified Registered Installer with the NZ Home Heating Association, of which Broady's are also a member. We can provide a list of these installers, or if preferred visit their website for a full and current list at www.nzhha.co.nz/membership.asp. By listing these Installers, it is not implied nor inferred that Broady's recommend them or their work. As the contract for installation is between you and the chosen Installer – payment is due directly to them, normally on the completion of the installation. Any possible issues regarding your installation are to be addressed to the Installer.

KEEP THEIR NAME ON FILE.

•ELECTRICAL / PLUMBING

If any electrical/plumbing work is required, it must be carried out by a licensed Electrician/Plumber. All electrical work must be carried out to AS/NZS3000 or AS/NZS3100 requirements, plumbing work carried out to appropriate requirements of AS3500.4.1 or NZS4603, and both electrical and plumbing to local regulatory authority.

•SAFETY WARNING

- Only use dry, well seasoned firewood. Never use driftwood or treated timber
- DO NOT use flammable liquids or aerosols to start or re kindle the fire
- DO NOT OVERFIRE – only use the high heat setting when lighting the fire and reloading. Once fire is alight reduce air slide control to lower setting. Over firing may result in the warranty becoming void.
- Replace damaged and worn out consumables like baffles, liners, air tubes, rope seals etc with genuine replacements to ensure the correct and safe operation of the fireplace.
- If hot water boosters or boilers are fitted the appliance must be connected to an open vented hot water system.
- Make sure the minimum safety heater-to-wall clearance distances are maintained between the heater and any heat sensitive materials (furniture, drapes, blinds etc)
- Solid Fuel heaters with glass doors are not to be used as an open fire.



August 2008

INSTALLATION STEPS

KEMLAN COUPE DOUBLE SIDED FIREPLACE BUILT IN MODEL

These installation instructions comply with AS/NZS2918:2001

Steps:

- 1: Non Combustible Floors:** positioned fireplace directly onto a concrete or other non combustible floor.
- 2: Combustible Floors:** position fireplace onto a floor protector with minimum thickness 80mm of non combustible material extending 500mm in front of each glass door opening and 300mm to each side. While the minimum thickness is 80mm, we recommend a thickness of at least 80-100mm to keep with the style of the fireplace. It is possible to raise the fireplace up to 400-500mm off the floor using non combustible materials.
- 3:** The unit must be surrounded on all four sides by a masonry, brick or aerated concrete (Hebel) cavity to the full height of the ceiling or a height not less than 600mm above the finished height of the firebox. Minimum depth 520mm and minimum width 1225mm.
- 4: Full Height Installation.** A register plate is set into the masonry cavity a minimum 450mm below the ceiling. Place insul-wool above the register plate. We recommend the masonry cavity extend to the full height of the ceiling. If timber is to be used at the upper level then the masonry must extend 100mm above the register plate (ie not less than 350mm below the ceiling).
- 5: Half Height Installation.** This design enables a view over the room dividing masonry cavity. The Hi-Therm flue is exposed up to the ceiling height. A ceiling plate should be installed over the flue exit of the cavity and plaster finished to create a level top to the masonry cavity.
- 6: Ventilation:** Air circulation vents are necessary. These are positioned on both sides of the masonry cavity, two at the bottom (min 230 x 100mm) and two as high up below the register plate (min 240 x 155mm).
- 7:** Care should be taken to allow for Schist or Stone on side(s) to owners design.
- 8: Minimum Clearances** to side walls is as follows:

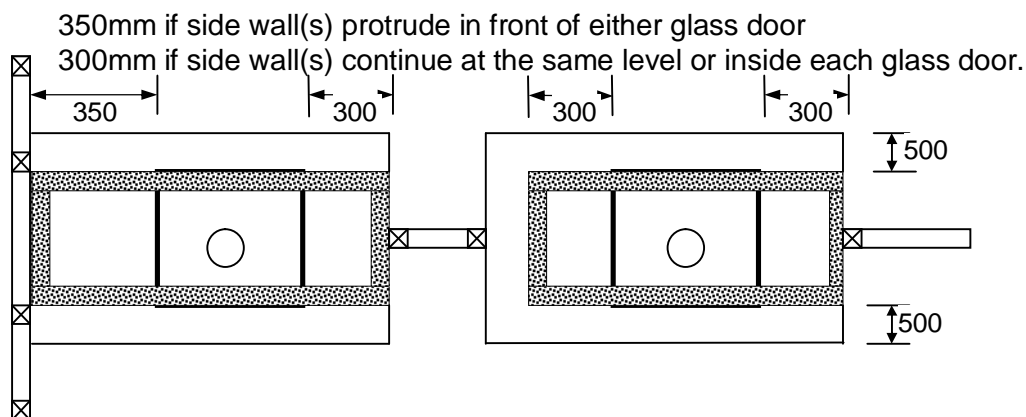

- 9: DO NOT** cover the non combustible cavity with Gib/Plaster Board or similar combustible material. This should be plastered and painted to match surrounding walls.
- 10: Seismic Restraint** – Remove one (or both) of the covers on the Pedestal and drill two holes in the bottom of the plinth. Secure with two appropriate Dyno bolts through plinth and floor protector into the floor surface below. Replace covers or fit fan to one side if being installed. Refer to AS/NZS2918:2001.

These specifications are at times updated, if unsure check with Broadys NZ Ltd.

Kemlan Coupe – Built In Model

Front Elevation

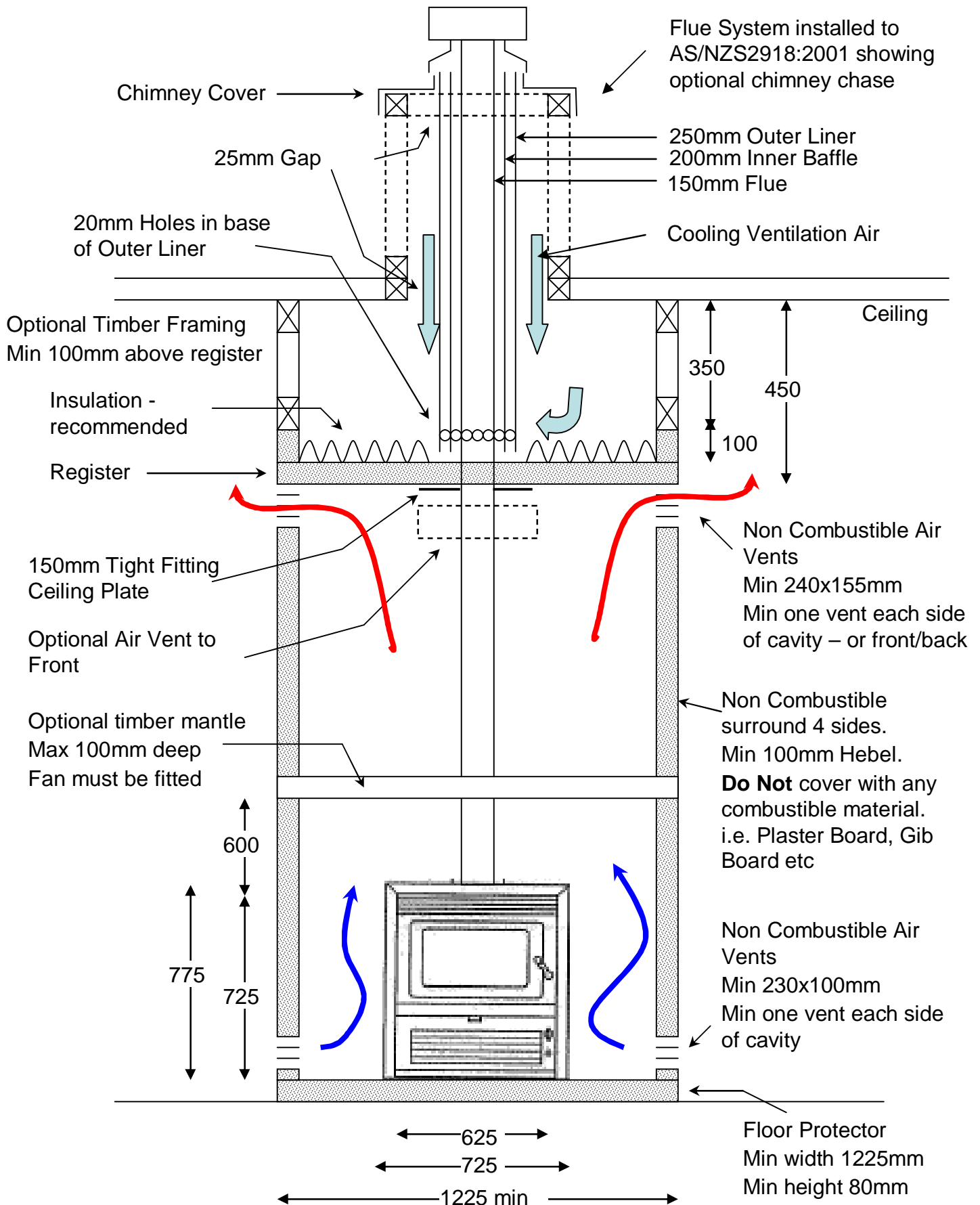

Kemlan Coupe – Built In Model

Side Elevation

Full Masonry

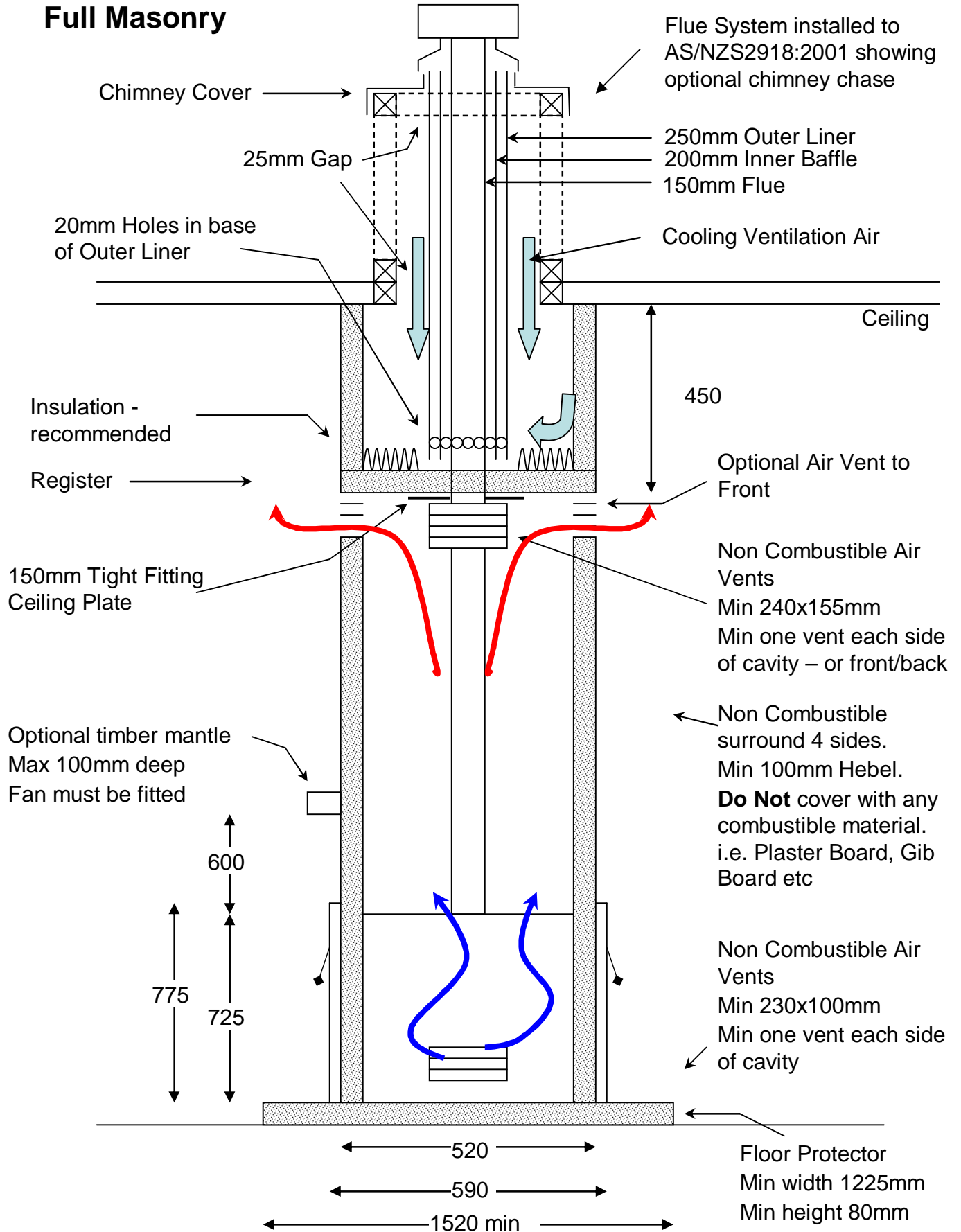

Kemlan Coupe – Built In Model

Front Elevation

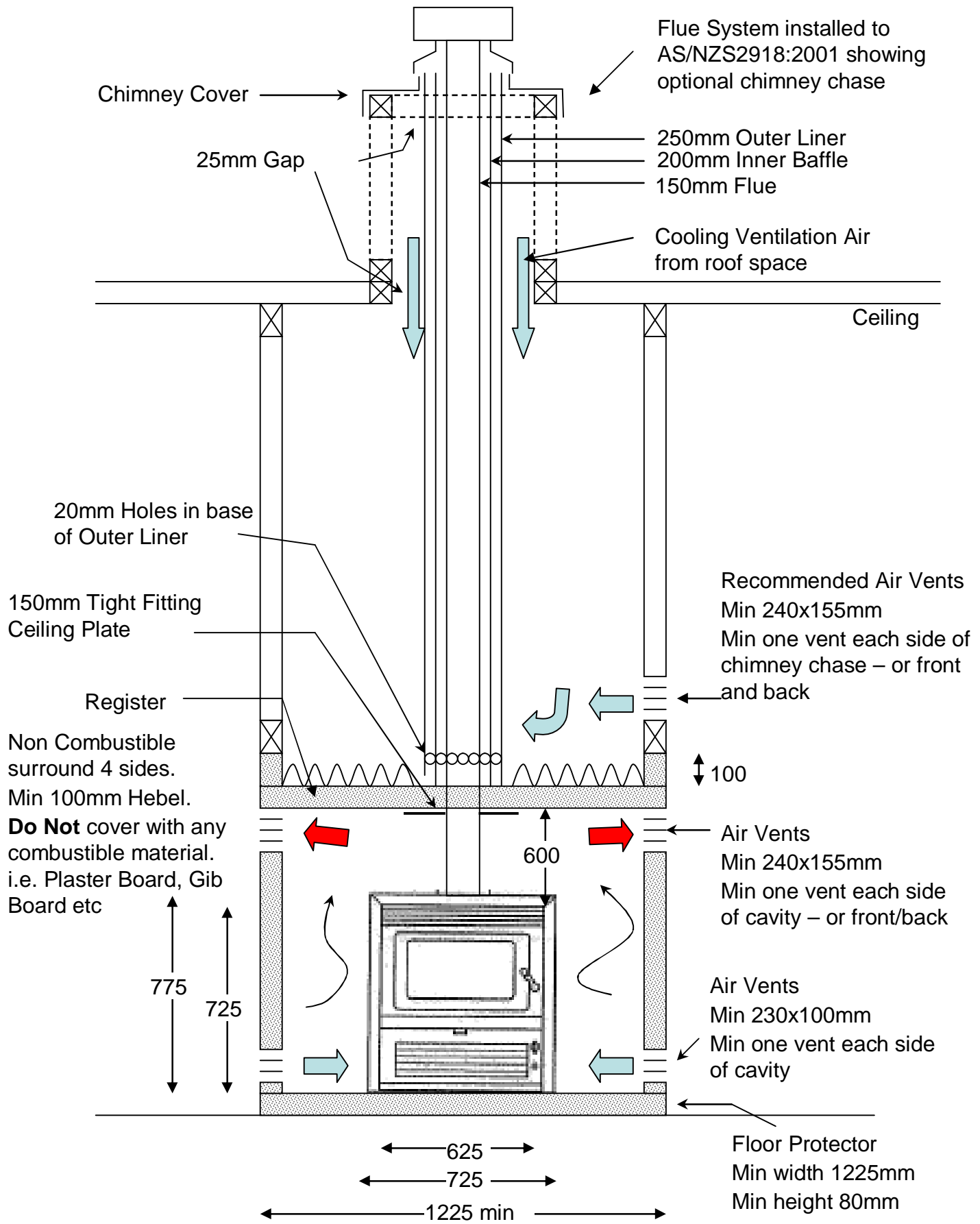

Kemlan Coupe – Built In Model

Side Elevation

Timber Over Masonry

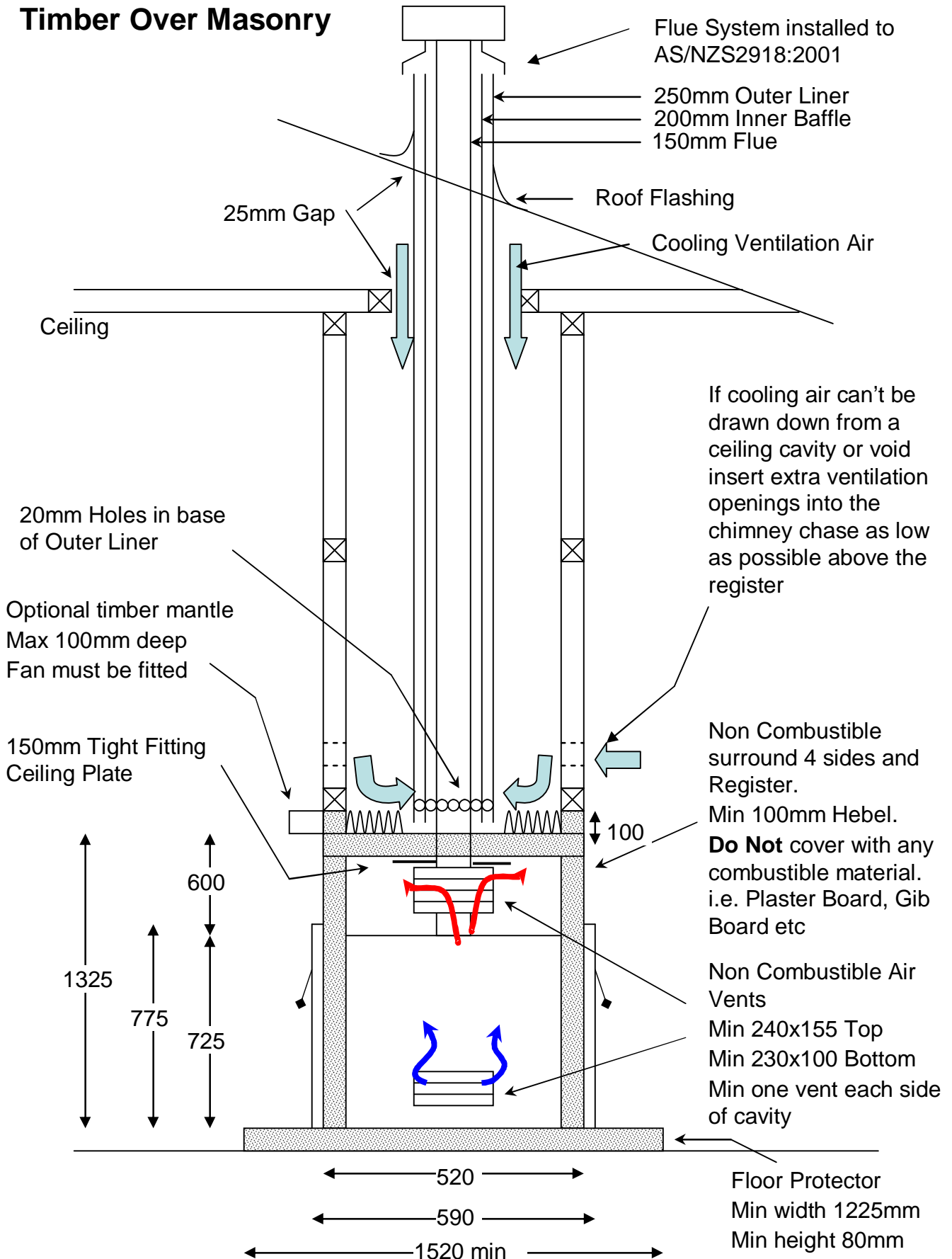

Kemlan Coupe – Built In Model

Side Elevation

Half Height Masonry

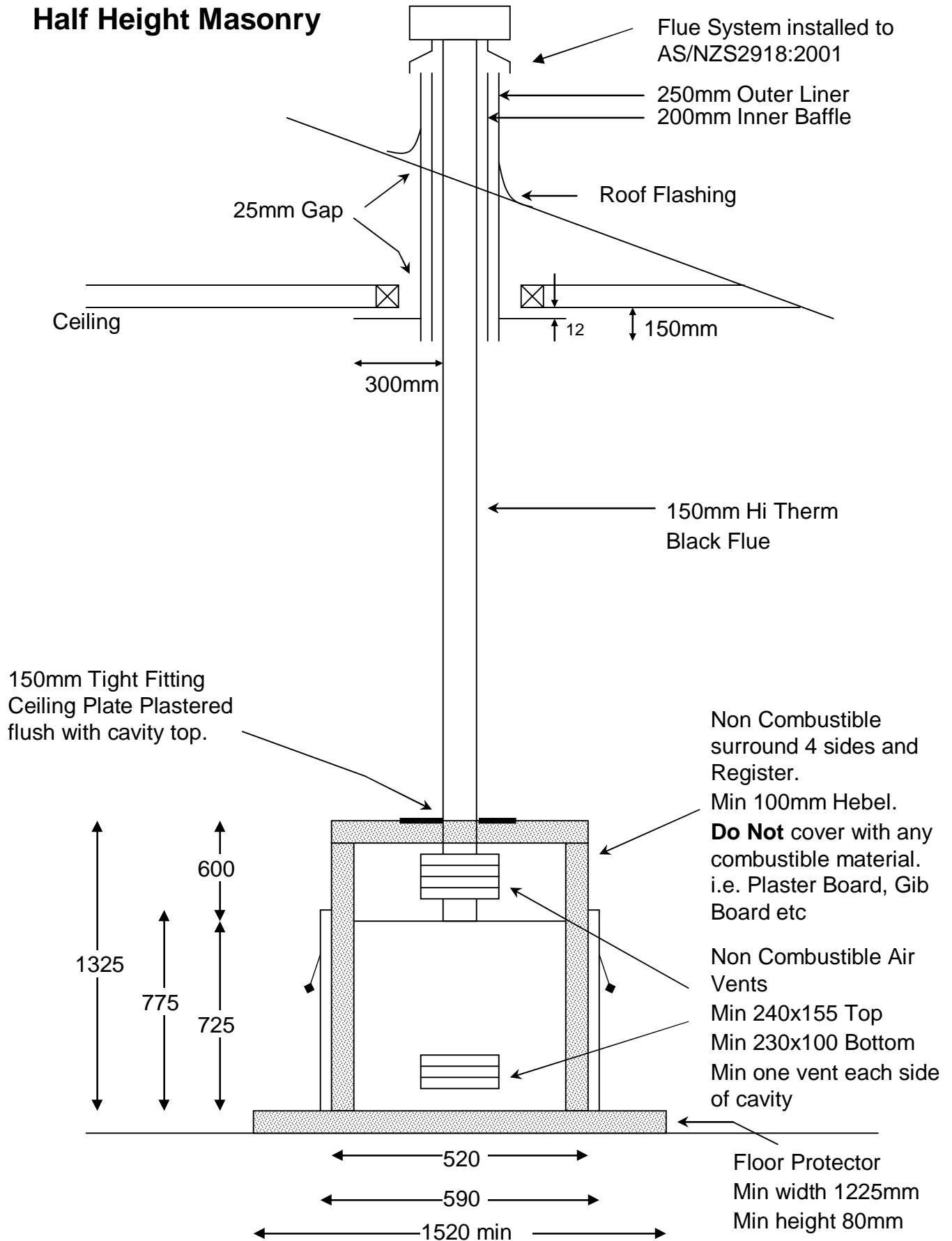

Installation Example Images



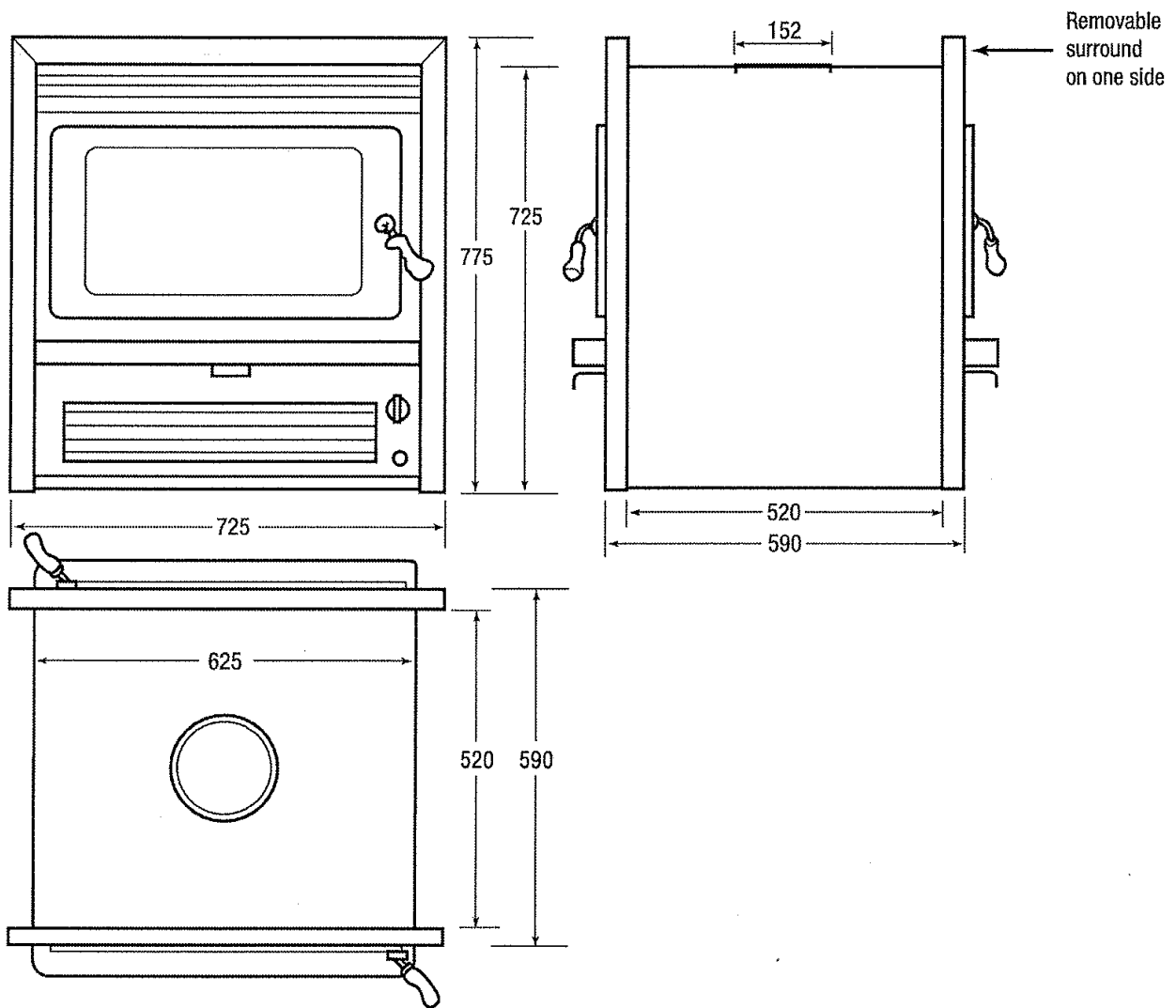

Notes:

BROADY'S NZ LTD

46a SIR WILLIAM AVENUE, EAST TAMAKI, AUCKLAND | PO BOX 58-183, GREENMOUNT, NEW ZEALAND
 TELEPHONE: 0-9-274 0658 | FACSIMILE: 0-9-272 2519 | EMAIL: enquiries@broadys.co.nz | WEBSITE: www.broadys.co.nz